

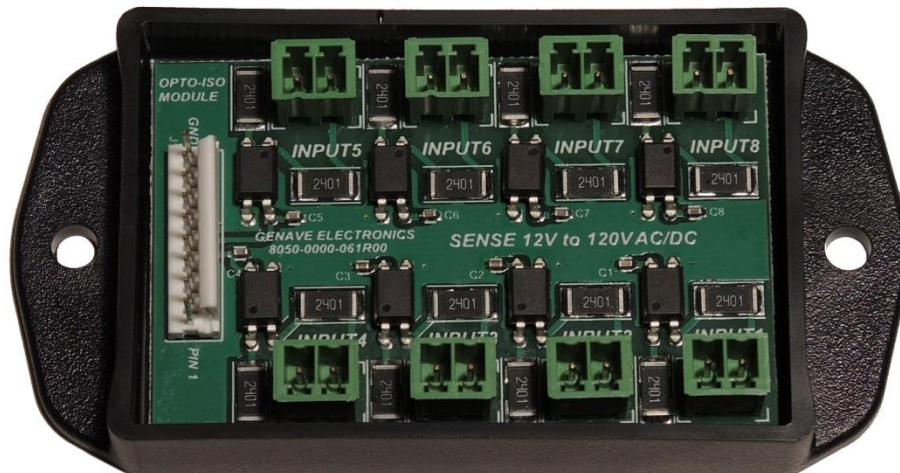

# IN-ISO

Input Isolation Module for RXC Equipment

## Install & User Manual



Genave / NRC, Inc.

[www.genave.com](http://www.genave.com)

[support@genave.com](mailto:support@genave.com)

Copyright 2017. Genave / NRC, Inc.

Tech. Publication No. 9000-0000-109 Rev 01



## **Warning**



If incorrectly used, this equipment can cause severe injury. Those who use and maintain the equipment should be trained in its proper use, warned of its dangers, and should read the manuals before attempting to set up, operate, adjust or service the equipment. Keep this manual for future reference.

# **Important Safety Information**

## **Installation & Service Precautions**



• Electrocutation, severe personal injury and damage to equipment can occur during installation or servicing this equipment. All electrical work should be performed by, or under the supervision of an experienced electrician and in accordance with all applicable electrical, fire, building and safety codes.

• You must test the system and equipment to insure it is operating correctly after the installation, as well as after any work has been performed.

## **System Operation**

• Training is necessary to ensure those responsible can correctly use the system. Periodic tests can serve to accomplish the training for the operators, in addition to verifying system readiness.

• You must carefully read and completely understand all the information about the system including its abilities and its limitations. Since no control system is infallible, you must have contingency plans for control, in the event the primary systems do not perform as expected, for any reason.

# IN-ISO Install & User Manual

©2017, Genave/NRC, Inc.

## IN-ISO Hardware

Phone 651-460-6616

Fax 651-460-6686

### PRINTED IN USA

The contents of this manual are the property of Genave/NRC, Inc. and are copyrighted. Any reproduction in whole or in part is strictly prohibited. For additional copies of this manual or software, please contact Genave/NRC, Inc.

### Warranty:

**Genave/NRC, Inc. products are warranted to be free from defects in material and workmanship for a period of ONE (1) year from the date of shipment. Genave, during this period, will repair or replace any parts, which upon our examination appear to be defective in materials or workmanship. This warranty does not apply to defects, malfunctions or breakage due to improper installation, servicing, handling or use thereof, nor to units that have been damaged by lightening or other "Acts of God", excess current, reversed supply connection, nor to units that have had their serial numbers altered or removed. Equipment damaged in Acts of War, abuse, misuse, tampering, submersion or willful destruction will also void this warranty.**

**Prior to returning equipment for warranty repair, contact the Genave Customer Service Department for an RMA number. They can be reached by using the telephone number or fax number listed above. Genave/NRC, Inc. (Genave) and its licensors offer this warranty in lieu of any and all other guarantees or warranties, either express or implied, including without limitation the implied warranties of merchantability and fitness for a particular purpose, regarding hardware or software. Genave and its licensors do not warrant, guarantee or make any representations regarding the use or the results of the use of the software or hardware in terms of its correctness, accuracy, reliability, most recent or otherwise. You assume the entire risk as to the results and performance. The exclusion of implied warranties is not permitted by some jurisdictions. The above exclusion may not apply to you.**

In no event will Genave, its licensors, directors, officers, employees or agents (collectively Genave's licensor) be liable to you for any consequential, incidental or indirect damages (including damages for loss of business profits, business interruption, loss of business information, and the like) arising out of the use or inability to use the software or hardware even if the Genave and/or its licensor has been advised of the possibility of such damages. Because some jurisdictions do not allow the exclusion or limitation of liability for consequential or incidental damages, the above limitations may not apply to you. Genave and its licensors liability to you for actual damages from any cause whatsoever, and regardless of the form of the action (whether in contract, tort, (including negligence), product liability or otherwise), are expressly excluded.

Genave reserves the right to make changes in specifications at any time and without notice. The information furnished by Genave is believed to be accurate and reliable, however, no responsibility is assumed by Genave for its use, nor infringements of patents or other rights of third parties resulting from its use. No license is granted under any patents or patent rights of Genave/NRC, Inc., its licensors or suppliers.

### Life Support Policy:

Genave/NRC, Inc. products are not authorized for use as critical components in life support devices or systems without the express written approval of the president of Genave/NRC, Inc. As used herein:

1) Life support devices or systems are devices or systems which, (a) are intended for surgical implants into the body, or (b) support or sustain life, or whose failure to perform, when properly used in accordance with instructions, can reasonably be expected to result in a significant injury to the user.

2) Critical component is any component of a life support device or system whose failure to perform can be reasonably expected to cause the failure of the life support device or system, or to affect its safety or effectiveness.

CSP, Communications Signal Processor, Genave Operating System, GOS, CSP-105, CSP-107, CSP-108, CSP-120, ALERT-600, SimpleRx, RXCPro, SR-418, ENC-9500, TTDMOD are Trademarks of Genave/NRC, Inc. The Genave name and logo are Registered trademarks of Genave/NRC, Inc. Touch-

Other names used in this manual are trademarks of their respective companies.

# Input Isolation Module

## Table of Contents

**Product Overview .....5**

- Basics ..... 5
- Installing the module ..... 6
- Connect to RXC ..... 7
- Testing the module ..... 7

## Product Overview

### Basics

The IN-ISO module isolates the input to the RXC from high voltage threats, spikes or ground loops.

In addition, the IN-ISO module allows the control of the RXC with AC or DC voltages and currents over greater distances than normally available to the RXC.

The IN-ISO module has 8 independent and isolated inputs that accept voltages ranging from 12V to 120V AC or DC. Since the opto-isolator is a current driven device, switches can be remotely placed at a great distance from the IN-ISO. As long as the current is sufficient to activate the opto-isolator, the input to the RXC will be held low (Active).

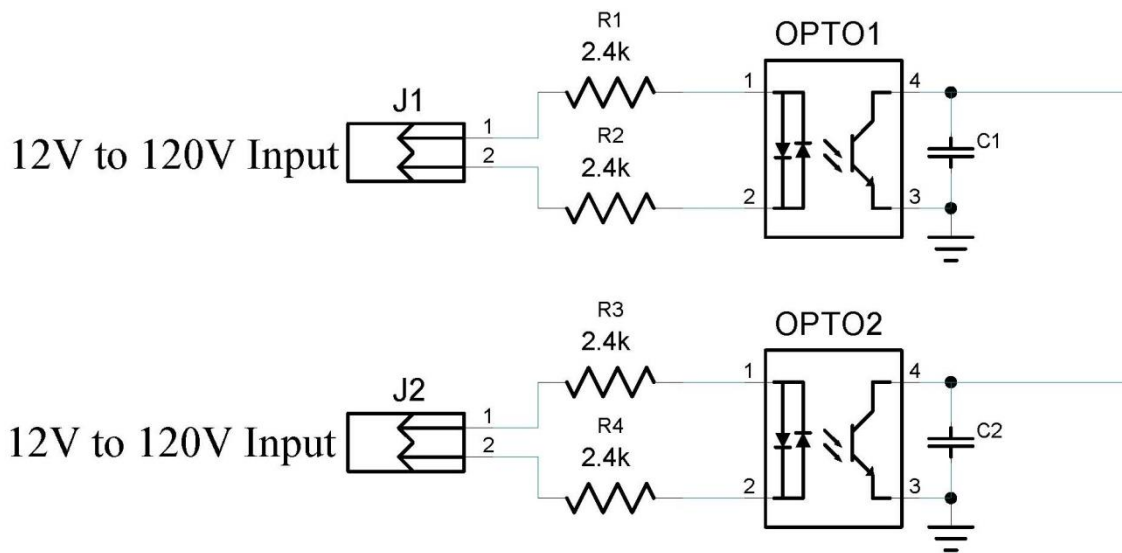

The image above shows inputs 1 and 2. The input impedance for each input is 4800 Ohms.

**Installing the module**

The IN-ISO must be installed in a weather tight enclosure. The distance between the two mounting holes is 3.5 Inches.

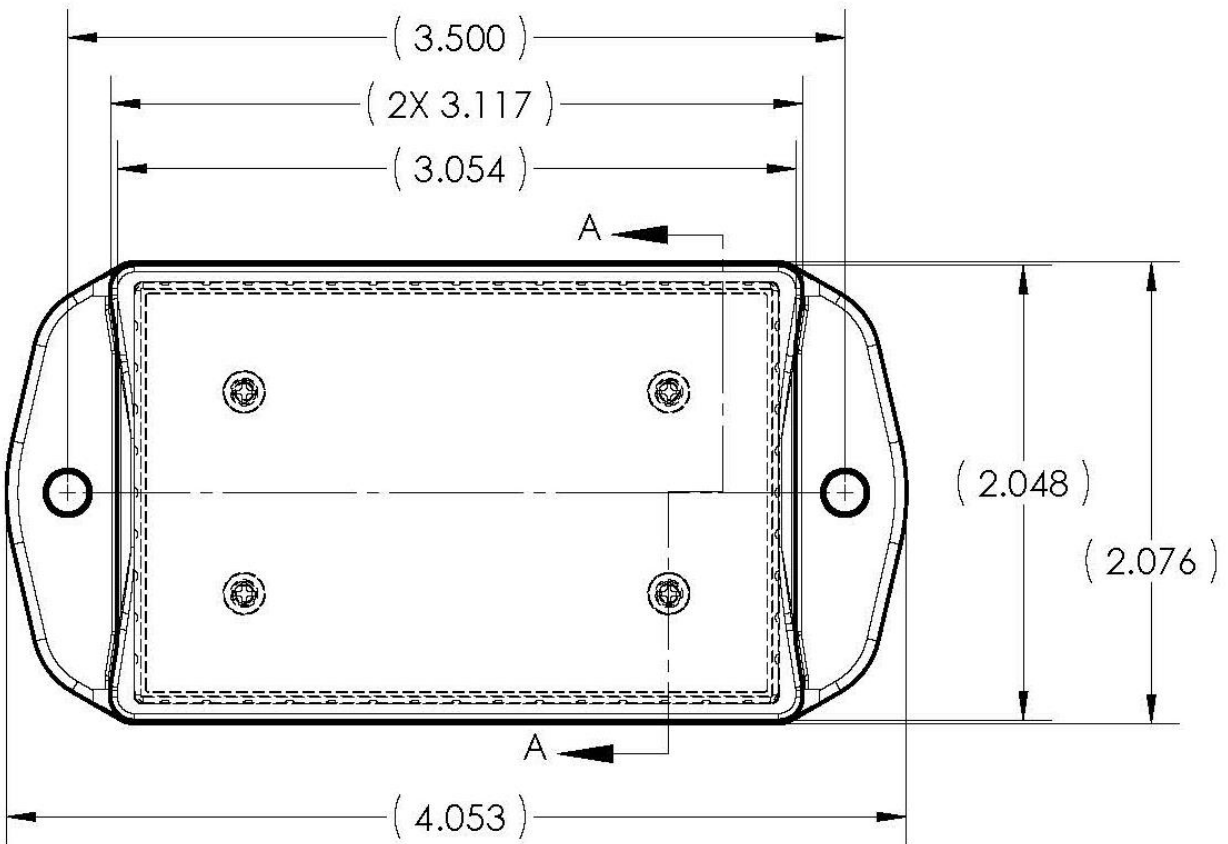

Connect to RXC  
Input J14  
"Remote Inputs"

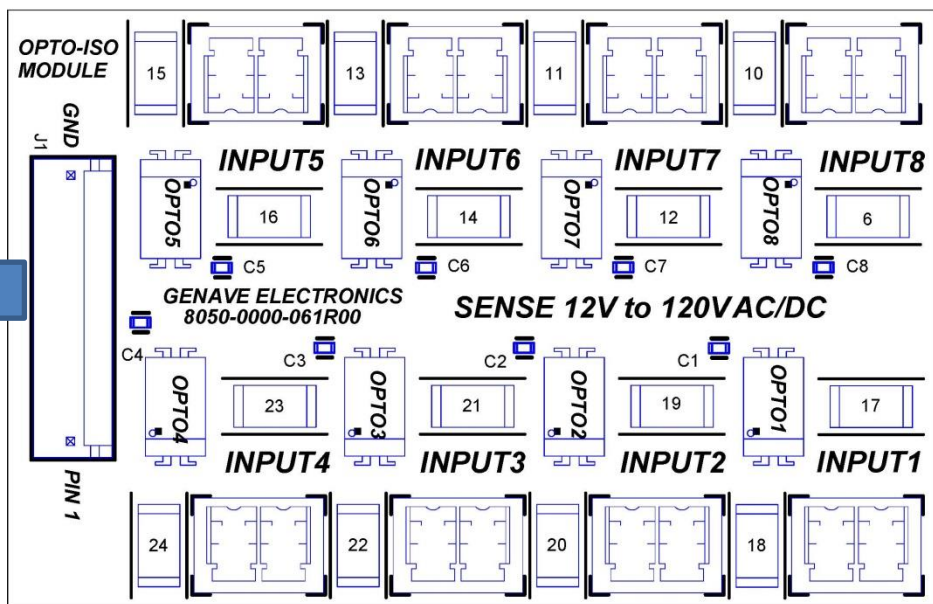
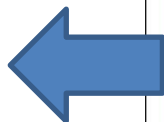

### Testing the module

Once the IN-ISO is installed, test each of the inputs. As each input is activated, the RXC will begin the action associated with the corresponding input. Inputs 1 through 4 will also show activity with the associated LED on the RXC being lit whenever the input is active.

**Schematic**

